

PKLSPEN Instructions

Lipstick Pen Kit

KIT FEATURES

- 24kt gold plated brass components, epoxy coated.
- Designed to simulate a woman's lipstick holder.
- Convenient compact purse size. Cap threads on back end.
- Uses a mini refill #PKMINI-R5
- Overall length: 3-1/2" (closed) 4-1/4" (in use).

REQUIRED ACCESSORIES

- 7mm pen mandrel
- 3-piece Bushing Set #PKLSBU
- 1/2" drill bit #PKDB12
- Universal pen blank squaring jig, or a 3/8" barrel trimmer with a spacer sleeve (included with bushing set)
- 2-part epoxy glue or insta-cure (cyano acrylate) glue.



DIAGRAM A – PEN PARTS

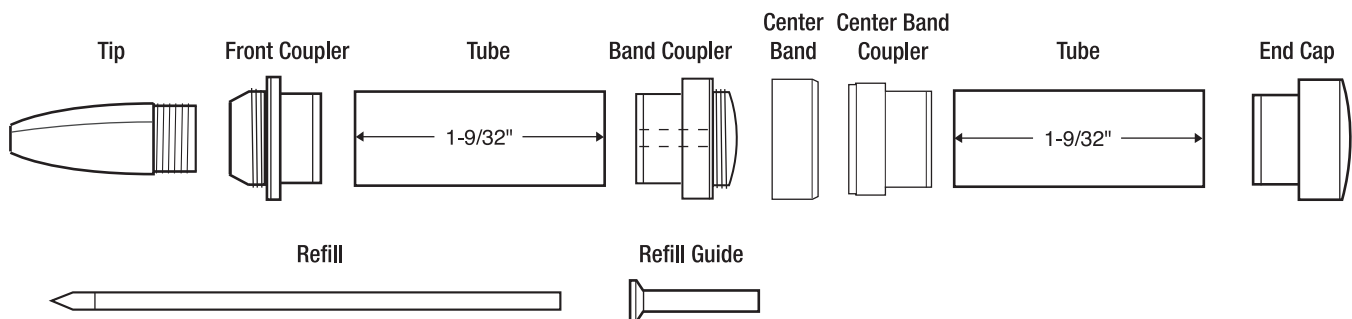

PREPARING THE BLANKS

- Cut 3/4" square blanks to the length of the brass tube (add 1/16" for squaring off).
- Drill 1/2" holes lengthwise through each blank.
- Spread glue over the tubes. Insert tubes into blanks with a twisting motion to spread the glue evenly inside. Center each tube lengthwise in the blanks.
- When the glue dries, square the ends of the blanks. Use the provided sleeve, insert over a 3/8" barrel trimmer shaft. Trim blanks as usual.

DIAGRAM B – Turning the Blanks

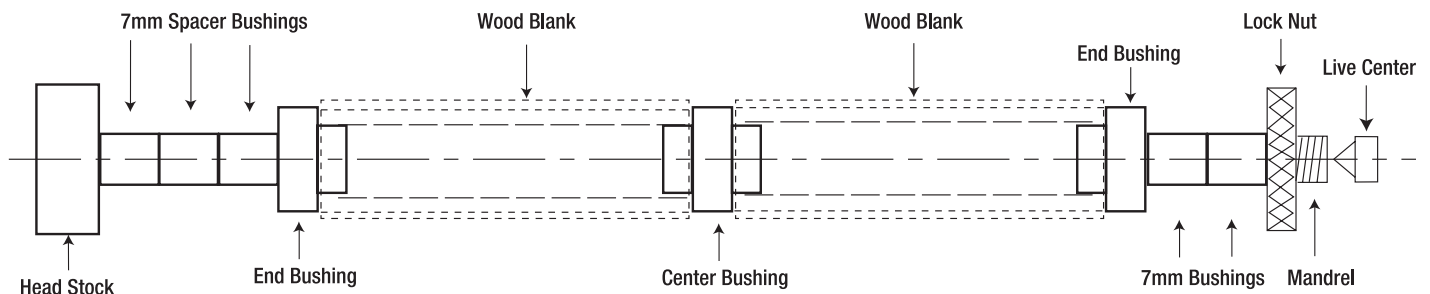

TURNING THE BLANKS

- Place spacer bushings on the mandrel. Insert an end bushing, wide end in first. Follow with a wood blank. Insert center bushing followed with the other blank. Insert another end bushing, narrow end in first. Use additional spacers to fill the space on the shaft to the threads if needed.
- Thread on the lock nut, hand tight to hold the items in place. Slide the tail stock snug to the mandrel shaft.
NOTE: Do not over tighten, it will damage the mandrel. Lock in place.
- Turn the wood down flush with the bushings using lathe tools and gradual higher grids of sand paper.
- Finish the barrels with your choice of polishes.

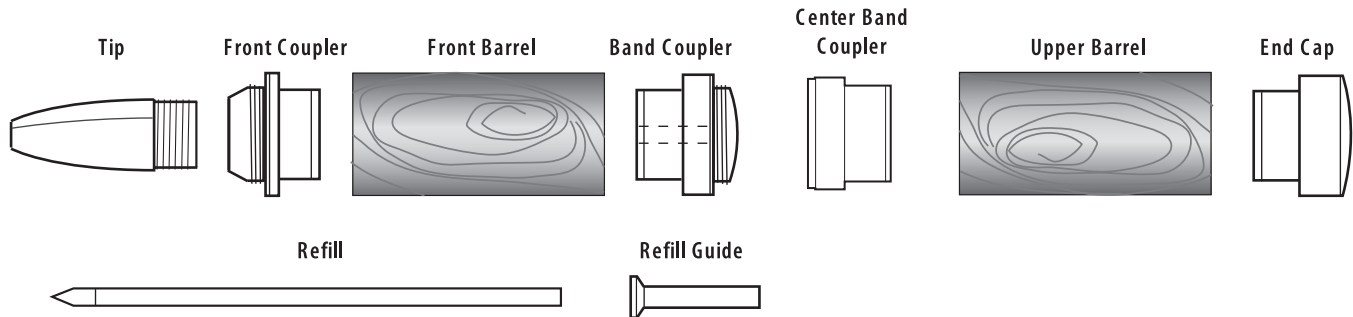
DIAGRAM C – ASSEMBLY**Assembly Note:**

- Line up pen parts according to **DIAGRAM C**.
- To press parts, use a pen press or a vice with covered jaws to avoid damage to the plated components.

ASSEMBLY

- Press the front coupler, recessed end in first into the front barrel.
- Place a drop of glue in the hole in the band coupler. Insert the narrow end of the refill guide in the hole to the end.
- Press the band coupler assembly, recessed end first, into the opposite end of the front barrel.
- Insert the refill through the front coupler into the hole in the refill guide and push refill to the end.
- Screw the tip into the front coupler.
- Press the center band and center band coupler together, recessed end in first and insert into the upper barrel.
- Press the end cap, recessed end in first into the opposite end of the upper barrel.
- Thread the completed upper barrel assembly over the tip/front barrel assembly. The pen is ready to use.

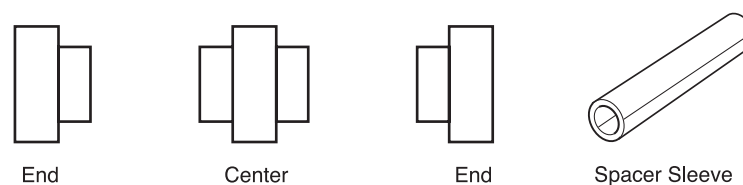
Diagram D – Bushing Set #PKLSBU

Philadelphia, PA 19115